



Application Guide Emergency Call Intercom



Benefits

- Clear, two-way Communication
- Simple Installation and Configuration
- User Friendly Controls
- Interfaces with Existing Phone System
- Easily Customizable and Expandable
- Flexible Connectivity
- Engineered and Built in the U.S.A.
- 36-Month Limited Warranty - See website for details

With large properties like shopping centers, or entertainment venues, communication isn't as simple as one person talking to another. Many times someone in a location such as a stairwell or parking garage needs assistance and when they push the button, they need to know someone will answer their call. Tech Works helps answer that call with our IC Series of intercom products. When a button is pushed at one of the remote locations, the central station is notified and an attendant can answer the call from the central station or even an optional cordless telephone.

How ever you choose to configure your system, rest assured Tech Works will help you answer the call.



Features

- | | |
|----------------------------|---|
| Redundant Circuitry | Allows for call processing even in the event of audio failure |
| Call Routing | Directly interface with existing PBX system |
| Cabling Schemes | Free topology wiring allows for flexibility |

Tech Works®

Making Specialized Communication Easy

1-800-813-1080 | www.tech4people.com



System Design Layout and Connections

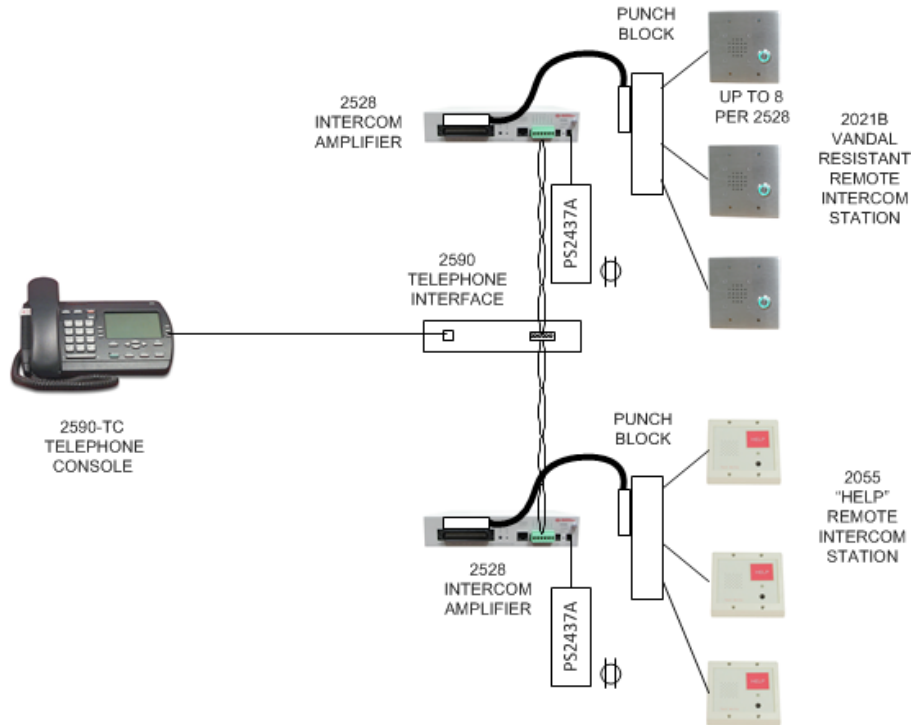

AREA OF REFUGE APPLICATION

System components

Part No.

2590-TC	Telephone/Master with Caller I.D. Display and Speed Dial
2021B	Vandal Resistant Intercom Speaker with Call Light and Call Switch
2055-W	Intercom Speaker Station with Call Cord Jack and Push-for-Help Button.
2590	Telephone Interface Master, RS232 Universal Network Bridge
2528	Intercom Amplifier - 8 Station Audio with Call-In & Confirmation Light, Rack Mount or Wall Mount
PS2437A	Power Supply 3.7 Amps, 24V DC, UL/CSA Listed with Mounting Bracket

