



The **FS-2-PLUS** is a rugged all metal assembly with two foot operated switches both normally open and normally closed contacts are available. Designed for the harsh environments of industrial machine control it can take any punishment the customer can dish out. The black painted exterior includes a rubber bottom pad and footpad to eliminate skidding.

The assembly includes the Foot Switch, a 15 foot rubber jacked cord, a locking Wall Jack, and white Nylon Single Gang Cover Plate. All connections are pre-wired and available on wire pigtails for your field connection.

Typical applications include Clean Room Intercom Call button where the professional staff is scrubbed and does not want to touch a conventional wall button or Control Room where hands are busy and feet are used for Push to Talk. Because both the normally open and normally closed contacts are made available the functional operation does not require opening the switch or rewiring to adapt to the functional requirement.

## **FS-2 PLUS FOOT OPERATED SWITCH**

### **BENEFITS**

- Easy to use
- Rugged Design
- Hands Free Operation
- Easy to Install
- Plug and Play
- No Special Tools

### **Design Information**

Metal Enclosure

Weight: 7 oz.

Dimensions: 7.94" L X 5.56" D X 1.38" H

### **Connections:**

Screw Terminals on FS-1

Wire Pigtail on FS-1 PLUS

### **Architects' & Engineers' Specifications**

A two position floor mounted foot switch assembly must be provided. The footswitch shall be an all metal design with dimensions 7.94" L X .565" D X 1.38" H. The foot switch shall have both normally open and normally closed contacts and include a 15 foot rubber cord with locking wall jack and white single gang wall plate.

The Foot Switch shall be Tech Works FS-2 PLUS.

# **Tech Works™**



"Making Specialized Communication Easy"

A Division of: **United Communication Technology, Inc.**

22347 La Palma Ave., Suite #107, Yorba Linda, CA 92887

Direct Line: **714-694-1040** Fax: **714-694-1041** Toll Free: **1-800-813-1080**

Web site **www.tech4people.com**

12/11

## Wiring of the FS-2 PLUS

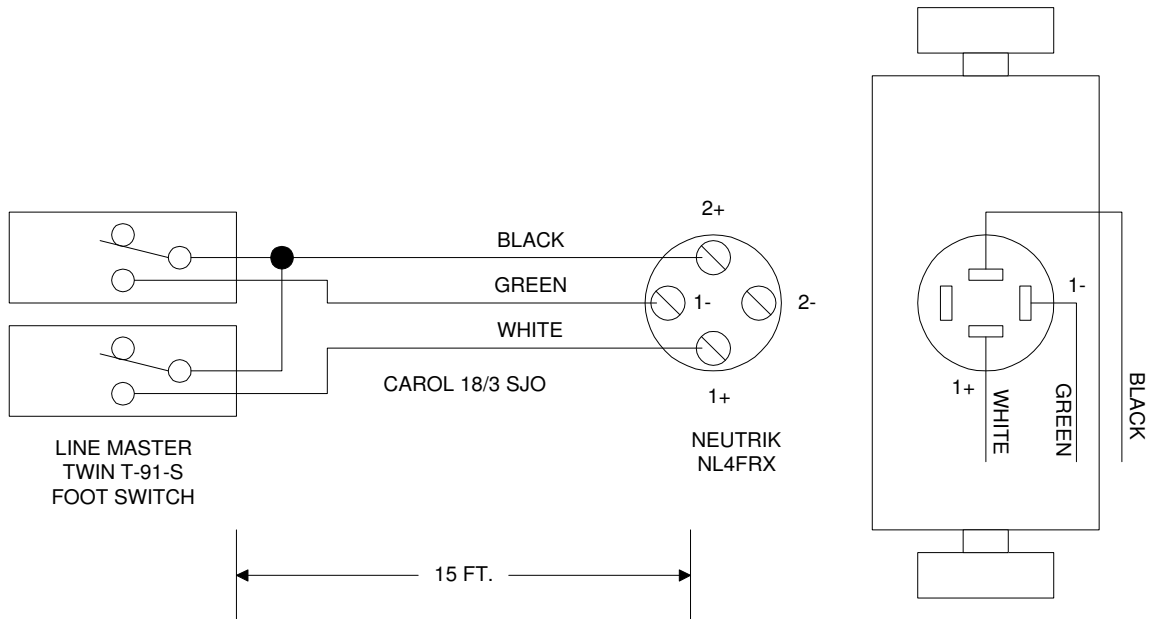

The Tech Works FS-2 has two separate foot pedals, each with a normally open contact. The Black wire is common to the swinger of both switches. The Green wire is the Normally open contact of one switch while the White wire is the normally open contact of the other switch.

The FS-2 can be used as either a Call Tone activation on 2 separate IC-52 systems or as a Push To Talk (PTT) on two separate IC-52 systems. It can also be used as a Call Tone activate with one pedal and a PTT with the other pedal all on one IC-52. By hooking the Black wire to the Common connection of both systems you then connect the White wire to one control contact and the Green wire to the other.

