



Application – Gate Intercom **Tech Works Solution - Voice-Call**

General Description -

When a large property required remote intercom at multiple entrances with a central security station, Tech Works answered the call. With each entrance being as far as 2 miles from the central station a fiber interface was proposed to handle the intercom and gate control. Standard intercom components were used with fiber transceivers to deliver clear communications to each entrance. When a guest arrives at one of the gates and presses the intercom button, the call is answered at the main security station on the property. The security guard has a telephone and a video monitor so that he can evaluate every person and their vehicle at the gate. Once he has verified who the person is and where they are going he can open the gate using a DTMF code on the 2590TC Telephone Control Console.

Basic system components:

Product	Purpose or Function
	User Interface Devices:
2590-TC	Telephone Console with Caller ID
2021	Correctional Grade Speaker Station w/ call button
	System Control Devices:
2528	High Power Intercom Amplifier supports up to eight 25-volt industry standard speakers
PSD-1270	Power Supply
	System Interface Devices:
2590	Telephone interface module supports any consumer grade corded or cordless telephone w/ CID

Benefits of using Tech Works –

- Distributed processing allows for easy installation and configuration of each calling station.
- Intuitive telephone operation provides clear two-way communication and requires little or no training for staff members.
- Redundant circuitry allows for call processing even in the event of audio failure.
- Direct interface with PBX (if desired) for call routing.
- Free Topology Wiring allows flexible cabling schemes.

Tech Works™



"Making Specialized Communication Easy"

A Division of: ***United Communication Technology, Inc.***
22347 La Palma Ave., Suite #107, Yorba Linda, CA 92887

Direct Line: **714-694-1040** Fax: **714-694-1041** Toll Free: **1-800-813-1080**

Web site **www.tech4people.com**

System Design Layout and Connections -

Security Gate Remote Intercom

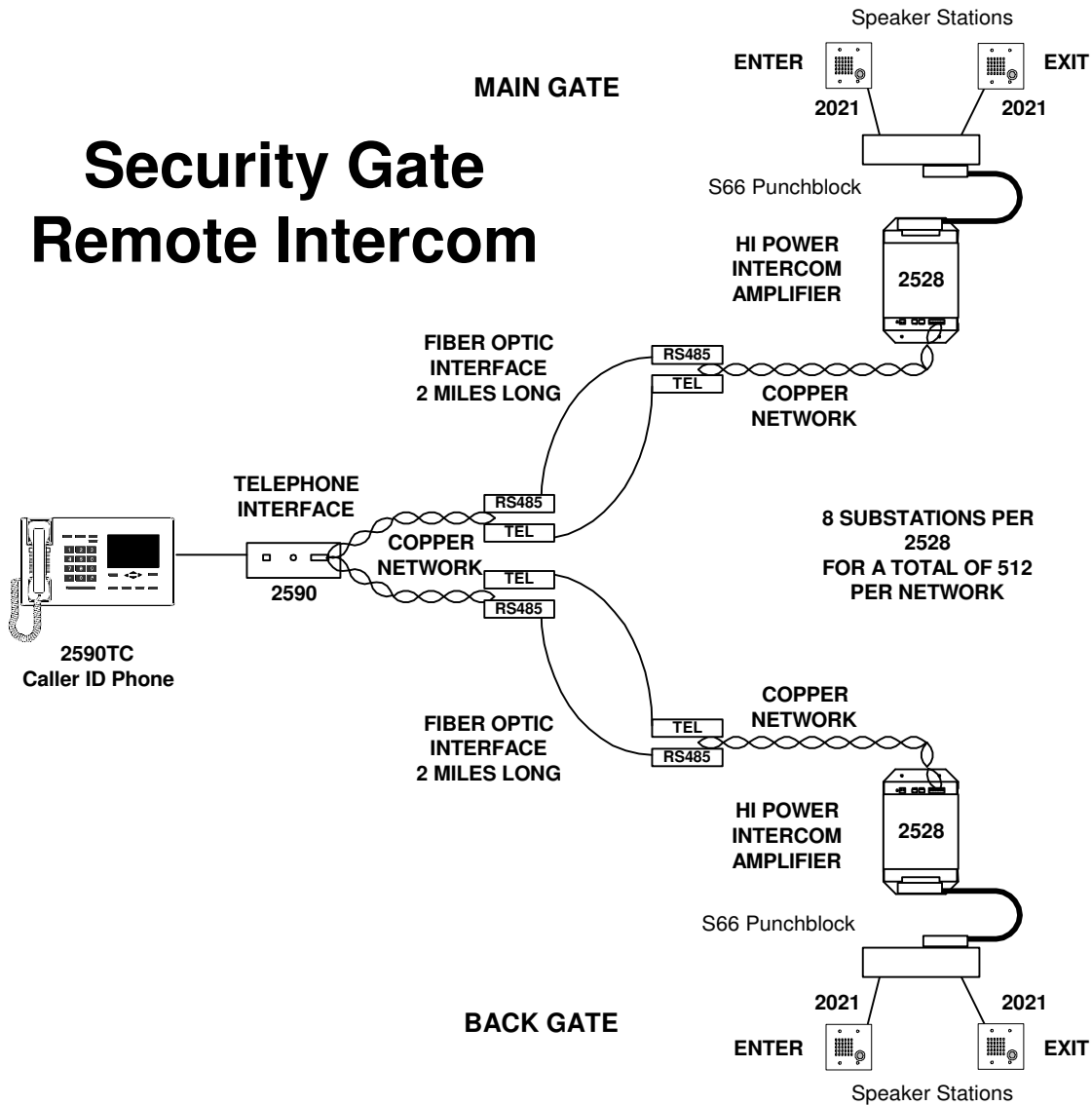

Components –

<u>Qty</u>	<u>Part #</u>	<u>Description</u>
1ea	2590-TC	Telephone Console w/ CID
1ea	2590	Telephone Interface
2ea	2528	High Power Intercom Amplifier
4ea	2021	Correctional Grade Speaker Station w/ call button
2ea		RS-485 Fiber Transceiver
2ea		Two Channel Audio Transceiver
1ea	PSD-1270	Power Supply

Video equipment not included.